



PRELIMINARY

CNX-P2140 User's Guide

V1.2

December 14, 2006



Summary of Notices & Disclaimers

CarNetix limited warranty is contingent upon proper and normal use and installation, and does not cover damage due to external causes, including but not limited to, accident, problems with electrical power, improper installation techniques or materials, liquids, chemicals, oxidation, corrosion, exposure to the elements, servicing not authorized by CarNetix, usage not in accordance with product instructions or specifications, failure to perform required preventive maintenance, and problems caused by use of parts and components not supplied by CarNetix.

CarNetix makes no express warranties or conditions beyond those stated in this warranty statement. CarNetix disclaims all other warranties and conditions express or implied, including without limitation implied warranties and conditions of merchantability and fitness for a particular purpose. Some states do not allow limitations on how long an implied warranty lasts, so the above limitation may not apply to you.

CarNetix does not accept liability beyond the remedies set forth in this warranty statement or liability for incidental or consequential damages, including without limitation any liability for products not being available for use or for lost data or software.

CarNetix full warranty and return policies are stated in Section 5.0 at the end of this document.



1.0 Introduction.....	4
2.0 Specifications.....	6
2.1 CNX-P2140 Specifications.....	6
2.2 CNX-PSUmoni2140 Specifications.....	7
3.0 Jumper Settings.....	10
4.0 Current Limits.....	12
5.0 Applications Wiring Diagrams.....	13
5.1 J1 (Input Power Connector) Pin Functions.....	13
5.2 J2 (Output Power Connector) Pin Functions.....	14
5.3 Mac mini Application Diagrams.....	15
5.4 AOpen Pandora Application Diagrams.....	17
5.5 Xenarc Application Diagrams.....	19
5.6 Installing a CNX-P5V in the CNX-P2140.....	21
6.0 Pulse Start Feature.....	22
6.1 Pulse Start Connections.....	22
6.2 Pulse Start Operation.....	22
6.2.1 What is a pulse?.....	22
6.2.2 Starting the PSU with a pulse.....	23
6.2.3 Stopping the PSU with a pulse.....	23
6.2.4 Prolonging the Shutdown Delay State.....	23
6.2.5 Shutting down the PSU with double pulses.....	23
6.2.6 Ignition Override.....	23
7.0 Conditions of Use.....	24

1.0 Introduction

The CNX-P2140 is the most powerful and intelligent regulator ever built for the CarPC market. USB connectivity to the PSUmoni(TM) power supply monitor application takes the guesswork out of installation, setup, and operation. Real-time gauges show exactly what's going on under the hood! "Soft jumpers" let you tweak any parameter to your heart's content. Firmware updates via the USB port allow you to keep your product updated with the latest firmware with no special programming hardware required. There is not other product like it on the market!

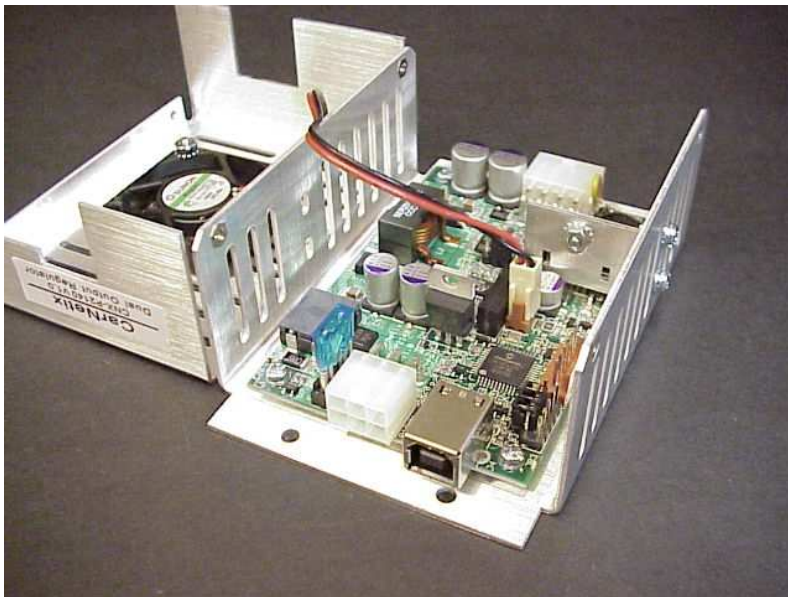

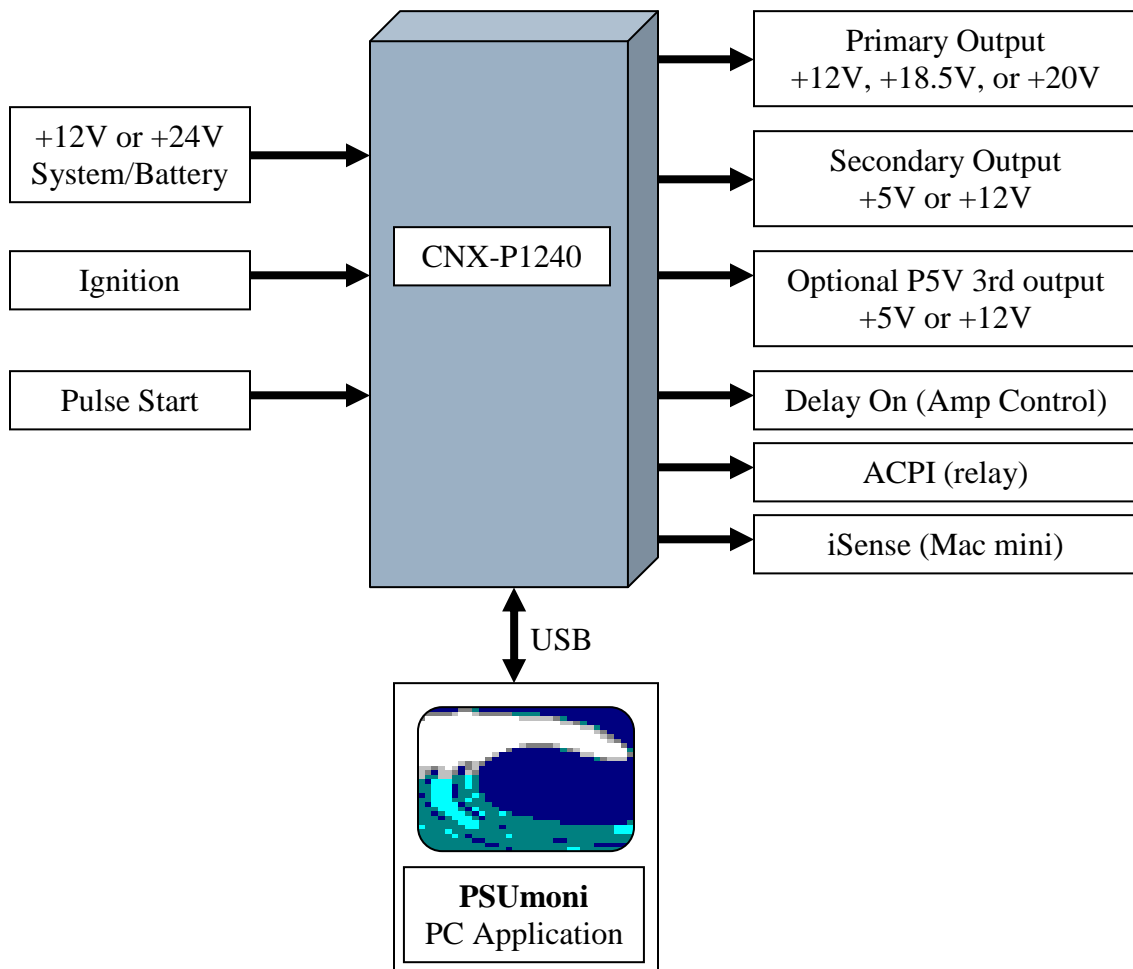

Figure 1 CNX-P2140 Block Diagram



2.0 Specifications

2.1 CNX-P2140 Specifications

Input Voltage Range

+7.5VDC to +34VDC (ie +12VDC or +24VDC Systems)

Input Voltage Range Selection

Survives engine cranking

Primary Output Voltage

Fully Automatic (no jumpering required)

Secondary Output Voltage

+12V, +18.5V, +20V Jumper Selectable

+5V, +12V, +13.2V jumper selectable

Maximum Output Currents *

(* these ratings depend upon jumper configurations of the primary and secondary outputs)

Battery Voltage	Primary Output Voltage	Max Primary Current	Primary Output Power	Secondary Output Voltage	Max Secondary Output Current	Secondary Output Power	Total Output Power
12V	12V	11A	132W	5V	3A	15W	147W
12V	12V	11A	132W	12V	N/A	-	-
12V	20V	7.5A	150W	5V	3A	15W	165W
12V	20V	7.5A	150W	12V	3A	36W	186W
24V	12V	10A	120W	5V	3A	15W	135W
24V	12V	10A	120W	12V	3A	36W	156W
24V	20V	11A	220W	5V	3A	15W	235W
24V	20V	11A	220W	12V	3A	36W	256W

Overall Operating Efficiency

~93% at loads > 2 amps

Idle Current

~60mA

Operating Temperature Range

-10°C to +60°C

Thermal Protection

Automatic shutdown @ > +60°C

Jumpers & Configurations

"Soft Jumpers" for many functions and delays (see PSUmoni specs for details)

Cooling Fan

Auto-sensing for +12V or +24V system (no jumpering required)

Can be used without fan for low power applications (soft jumper selectable)

Startup/Shutdown Controller (SSC)

Intelligent state-machine based SSC

Processor

PIC 18F4455 flash microprocessor with full speed USB

Firmware Upgrade

Via USB port. Download firmware upgrades from website

SSC Interface

Full Speed USB 2.0



SSC Application Interface
Input/Output Power Cables
Chassis Dimensions

PSUmoni 2140 Windows application
Pin compatible with standard CNX-P2140, MacPac, AOPak, and XSC8 power cable kits
4.6" x 3.25" x 1.75" (L x W x H) or 117mm x 83mm x 45mm.

2.2 CNX-PSUmoni2140 Specifications

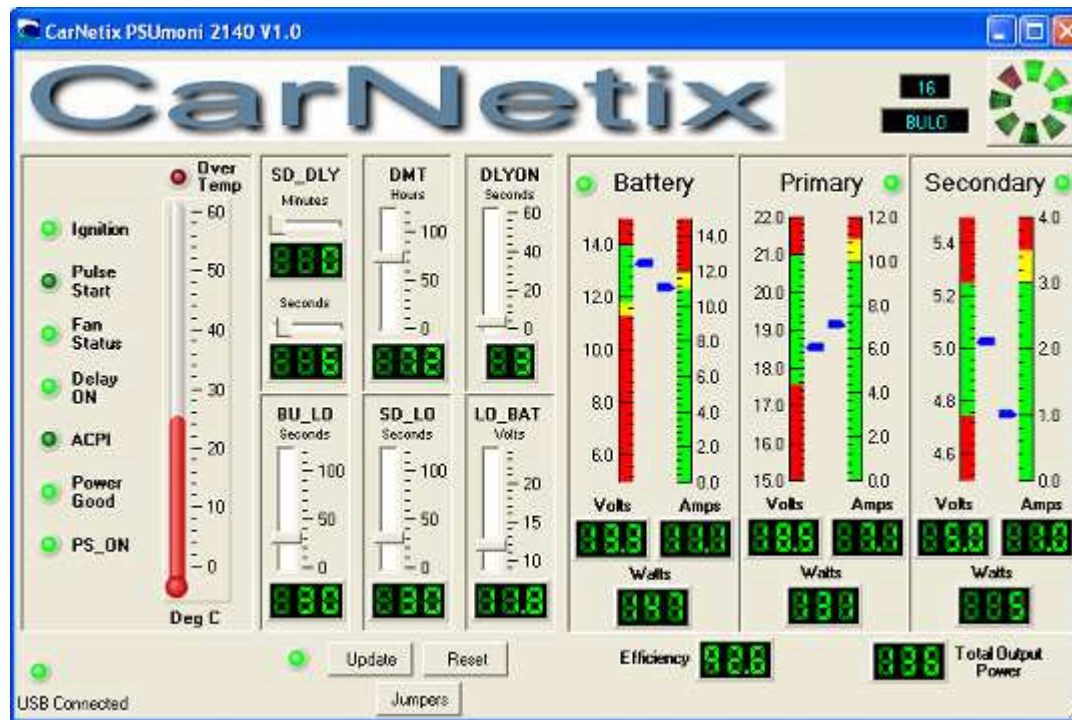

Figure 2 PSUmoni Screen Shot



Connectivity with CNX-P2140

Full speed USB 2.0

Analog Monitor Points

Battery Voltage (Auto ranging 12V/24V systems)
Battery Current
Input Power
Primary Output Voltage (Auto ranging +12/+18.5/+20V scale)
Primary Output Current
Primary Output Power
Secondary Output Voltage (Auto ranging +12/+5V scale)
Secondary Output Current
Secondary Output Power
Total Output Power (Primary + Secondary)
Overall Efficiency (Total Output Power/Total Input Power)
Temperature (0-60°C)

Digital Monitor Points

Battery OK
Primary Output Current OK
Secondary Output Current OK
Machine State Indicator
State Timers
Ignition Status (On/Off)
Pulse Start Status (On/Off)
Fan Status (Ok/Fault)
Delay ON Status (On/Off)
ACPI (power button) Status (On/Off)
Power Good Status (Regulator On/Off)
PS_ON Status (Regulator Control On/Off)
USB Connection Status (Connected/Not Connected)
Shutdown Delay Time (Minutes 0-59, Hours 0-3)



Control Sliders

Deadman Timer (0-120 Hours)
DelayON Timer (0-60 Seconds)
Bootup Lockout Timer (0-120 Seconds)
Shutdown Lockout timer (0-120 Seconds)
Low Battery Detection Threshold (9V - 24V)

Soft Jumpers

Standby Mode (On/Off)
Secondary Output ON (Ignition/DLYON)
Secondary Output OFF (PriOut/Ignition)
Fan (Enable/Disable)

Firmware Upgrades

Firmware upgrades applied to P2140 via USB port

3.0 Jumper Settings

It is important that you properly set the hardware jumpers before applying power to the P2140. Please select the following:

- Primary output voltage (JP1)
 - Selectable for +12V, +18.5V, or +20V output
- Secondary output voltage (JP2)
 - Selectable for +5V or +12V output
- JP3 Option Jumpers
 - Various options utilize the JP3 jumper header. These include:
 - Pins 1-2: Pulse Start input connection (see section 6)
 - Pins 3-4, and 5-6 are unused at this time
 - Pins 7-8: Programming jumper used to upload new firmware (see the Firmware Upgrade Guide)
 - Pins 9-10: Used to control the optional P5V regulator (see section 5.6)
- Input to Secondary output regulator (JP4)
 - See JP4 configuration matrix for proper settings. Depends on battery voltage, primary output voltage, and secondary output voltage
- PC or Mac operation (JP5)
 - This sets the dual-function iSense/ACPI- output pin for the appropriate functionality. If using a PC, this setting completes the ACPI relay output circuit. If using a Mac mini, this output connects the iSense signal to the Mac.
- Mac mini classic or Intel Mac mini operation (JP5)
 - This jumper selects either a 6.8k resistor (Mac mini classic) or a 3.4k resistor (Intel Mac mini) for iSense.
- ACPI Isolated Relay Output (JP6)
 - This output is provided for those who were previously using a P1900 (or Xenarc PC-PSU19) so that you do not have to change the existing wiring. JP6 provides similar functionality to JP3 on the P1900 (i.e. isolated relay output for ACPI signal).

Figure 2 below shows the locations and settings for the various hardware configuration jumpers.

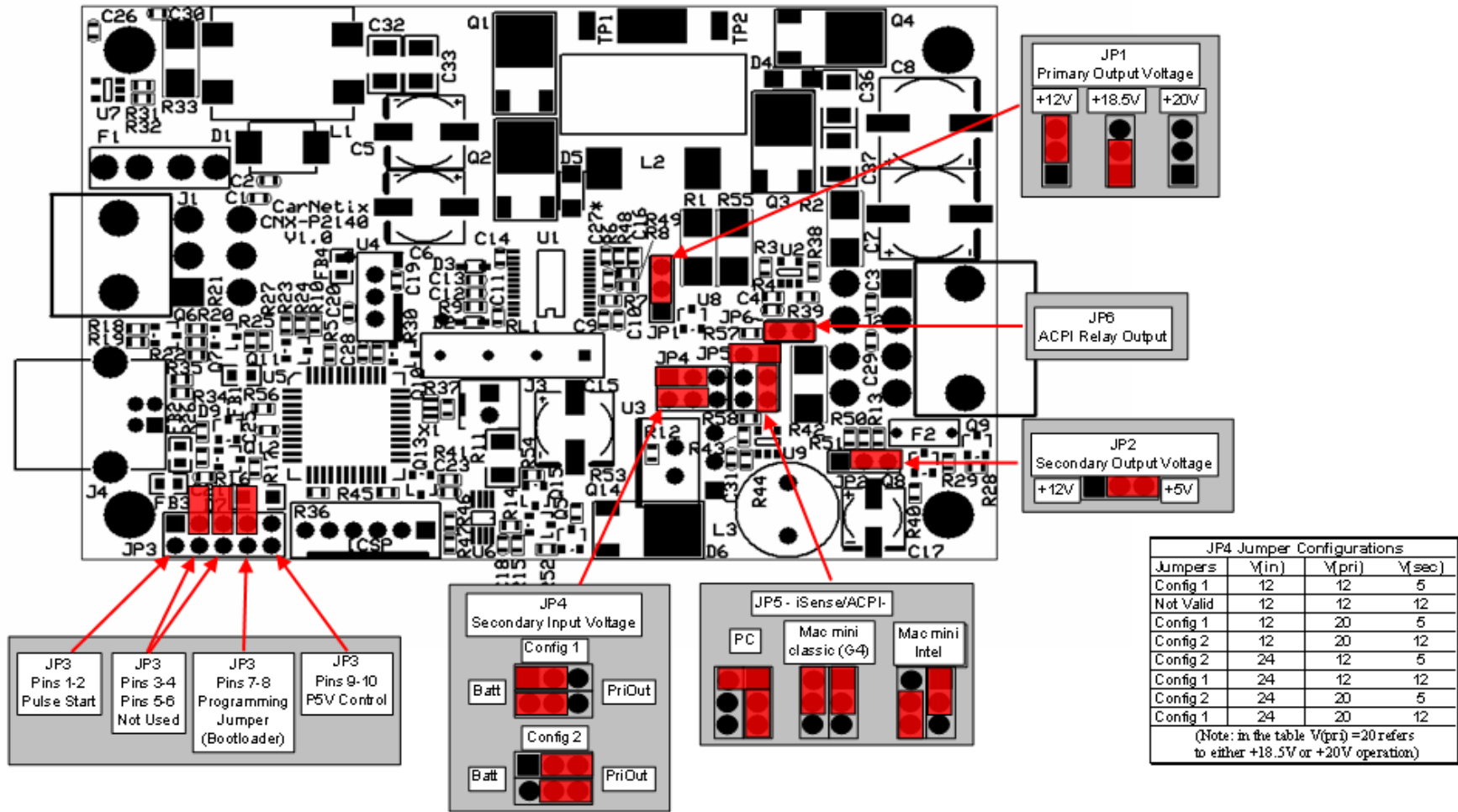

Figure 3 P2140 Jumper Locations and Settings



4.0 Current Limits

The flexibility of the P2140 allows the user to select several different operating configurations. Since the battery input can be either +12V or +24V, and the primary output can be +12V, +18.5V, or +20V, and the secondary output can be either +5V or +12V, the P2140 has various current limits depending upon the jumper settings. These current limits are summarized in the table below. If these current limits are exceeded, the P2140 will go into forced shutdown.

In the case where the input to the secondary output regulator is fed from the output of the primary regulator, the current limit is the sum of BOTH the primary and secondary currents. These configurations are shaded in the table below. The combined maximum current limit is shown in the right hand column.

(Note: in the table below V(pri) =20 refers to either +18.5V or +20V operation)

V(in)	V(pri)	I(pri)(max)	P(pri)	V(sec)	I(sec)(max)	P(sec)	P(total)	sec jumper	max i(pri)+I(sec)
12	12	11	132	5	3	15	147	batt	N/A
12	12	11	132	12	N/A	-	-	N/A	N/A
12	20	7.5	150	5	3	15	165	batt	N/A
12	20	7.5	150	12	3	36	186	pri	7.5
24	12	10	120	5	3	15	135	pri	10
24	12	10	120	12	3	36	156	batt	N/A
24	20	11	220	5	3	15	235	pri	11
24	20	11	220	12	3	36	256	batt	N/A

Table 1 P2140 Current Limits

In addition to the current limits above, when in standby, the P2140 will limit both primary and secondary output currents to .5 amps each. If the current of either output exceeds .5 amps, the P2140 will automatically exit standby mode and cut power to both outputs.

5.0 Applications Wiring Diagrams

5.1 J1 (Input Power Connector) Pin Functions

The connector comes with “pigtailed”, or short lengths of wire that allow you to splice longer runs of larger gauge wire from your battery and ground connections. J1 is the 6-pin input power connection from your battery and ignition signal.

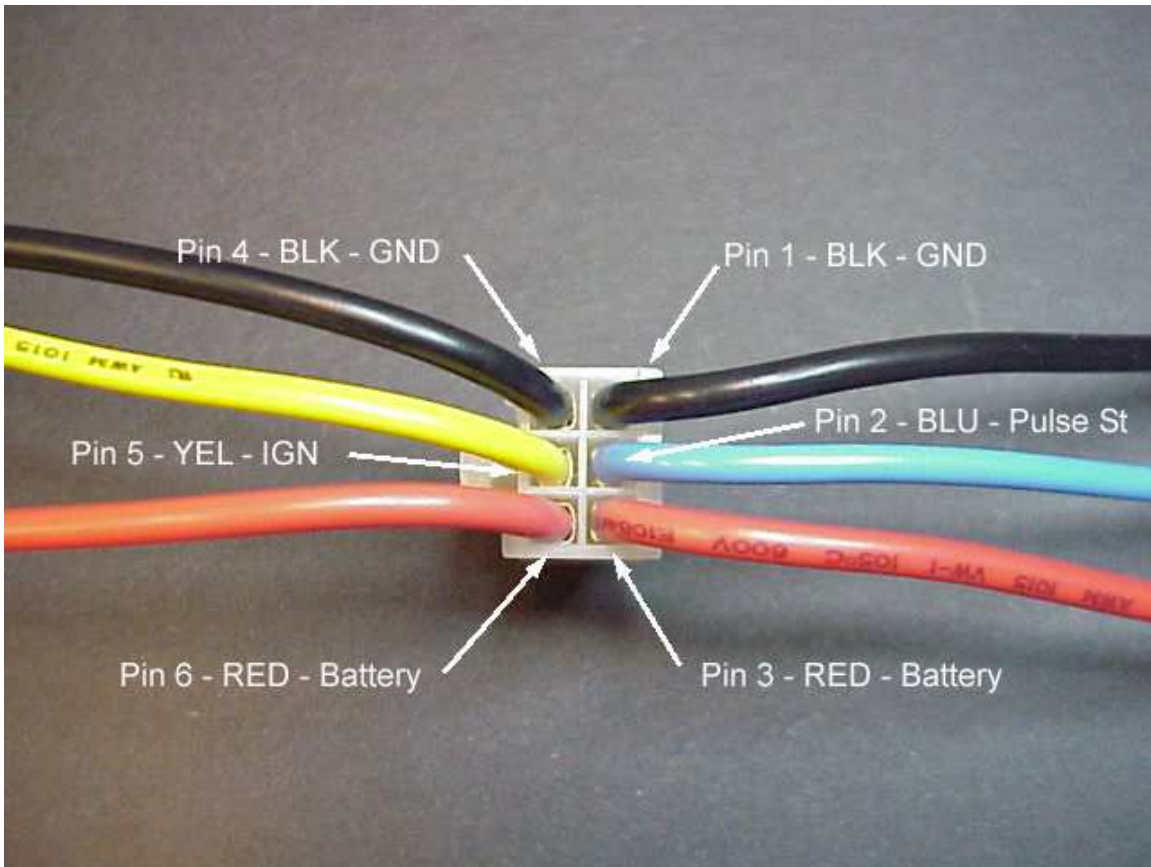

Pin	Wire Color	Function
1	Black	Ground
2	Blue	Pulse Start Input (See Section x)
3	Red	+12V Battery Input
4	Black	Ground
5	Yellow	Ignition/ACC input
6	Red	+12V Battery Input

Table 2 – P2140 J1 Pin Assignments

5.2 J2 (Output Power Connector) Pin Functions

The connector comes with “pigtailed”, or short lengths of wire that allow you to splice longer runs of larger gauge to your computer & peripherals. J2 is the 8-pin output power connector that feeds power to your PC, screen, USB devices, and other peripherals.

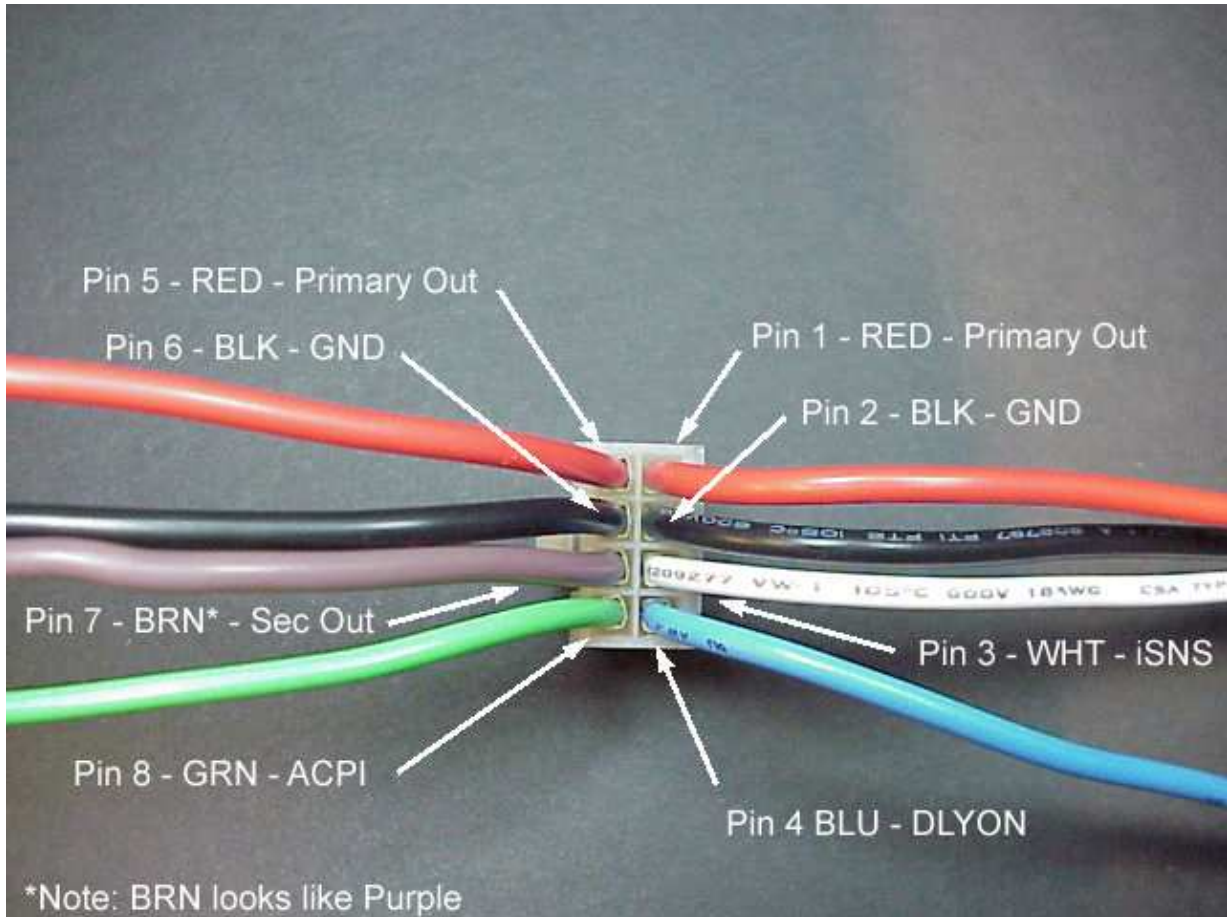

Pin	Wire Color	Function	Comment
1	Red	Primary Output 1	
2	Black	Ground 1	
3	White	ACPI-/iSense	Dual function, depends on jumper setting
4	Blue	DLYON Out	
5	Red	Primary Output 2	
6	Black	Ground 2	
7	Brown* (may look purple)	Secondary Output	
8	Green	ACPI+	

Table 3 – P2140 J2 Pin Assignments

CarNetix manufactures several power cable kits that simplify the installation of your P2140. When using these power cable kits, you will not need to use the "pigtail" power connectors that come with the P2140.

5.3 Mac mini Application Diagrams

Typical Mac mini Installation (Using MacPac Power Cable Kit)

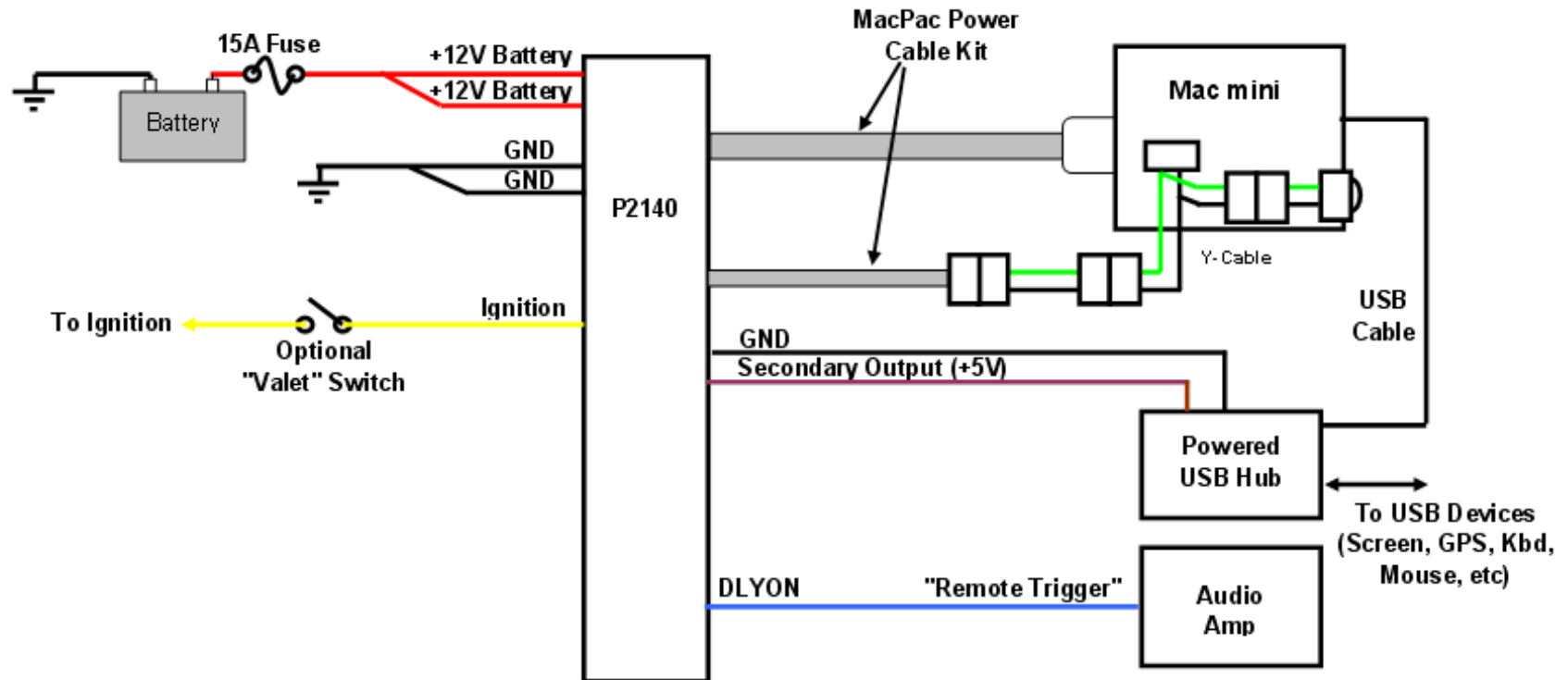

Typical Mac mini Installation (Using MacPac Power Cable Kit and P5V)

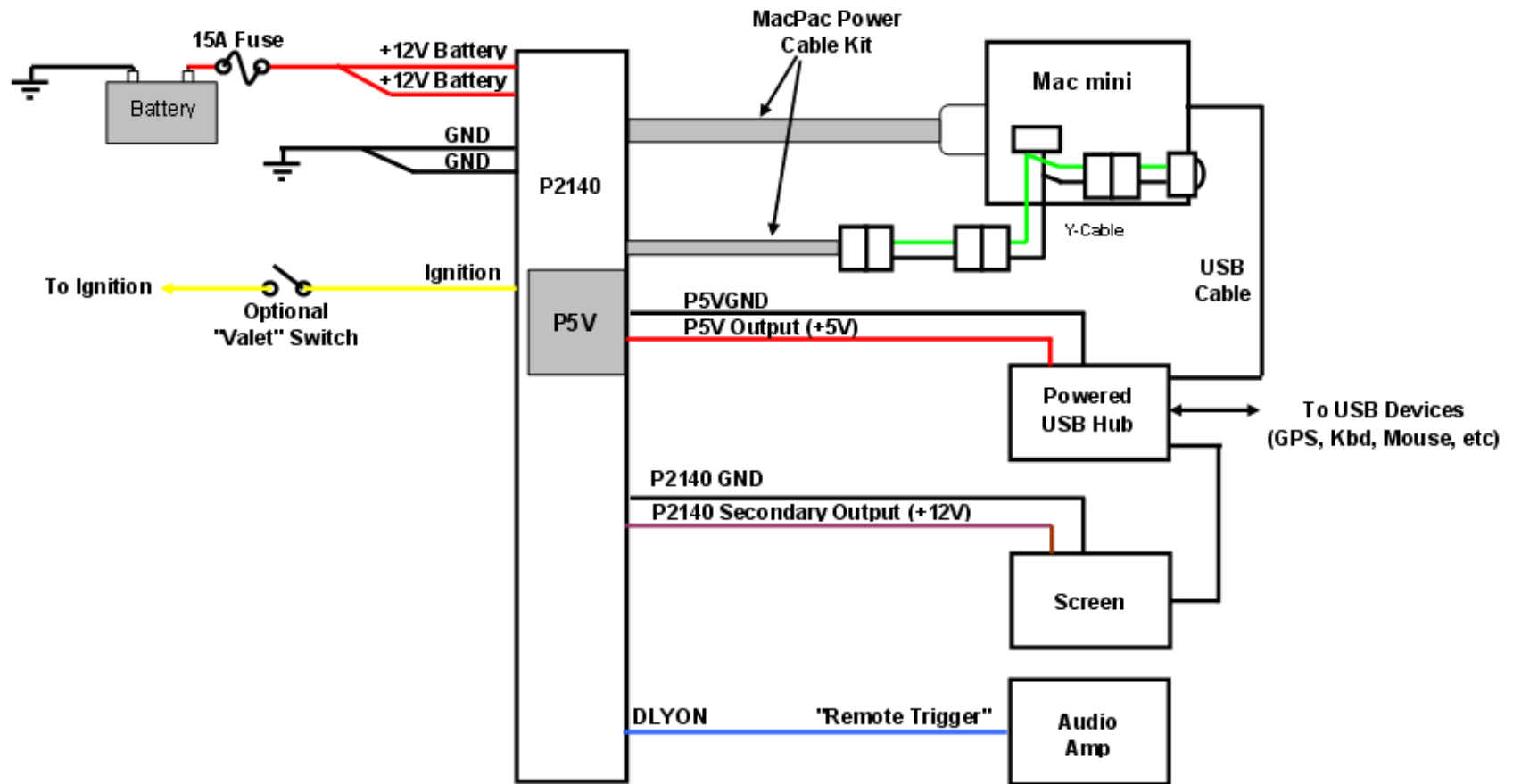

5.4 AOpen Pandora Application Diagrams

Typical AOpen Pandora Installation (Using AOPac Power Cable Kit)

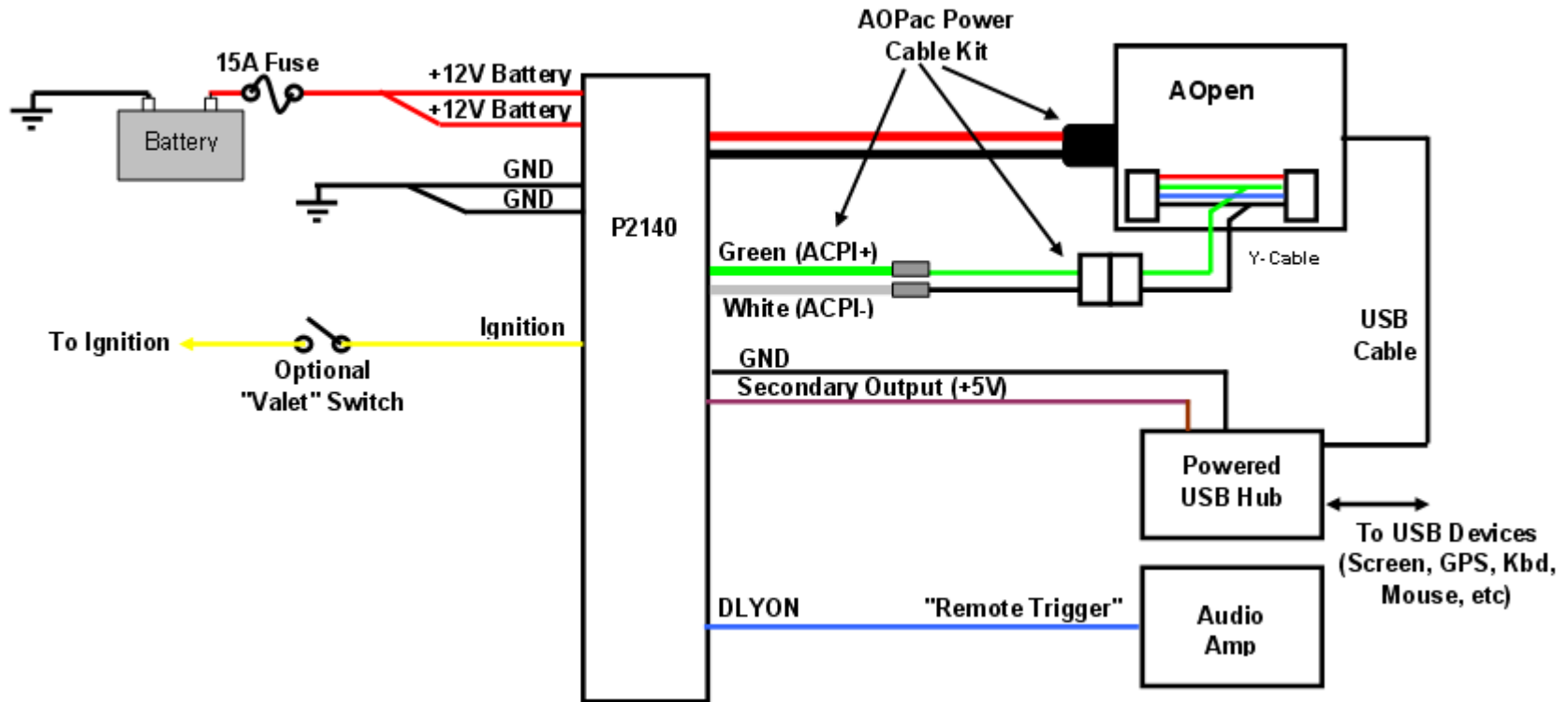

Typical AOpen Pandora Installation (Using AOPac Power Cable Kit and P5V)

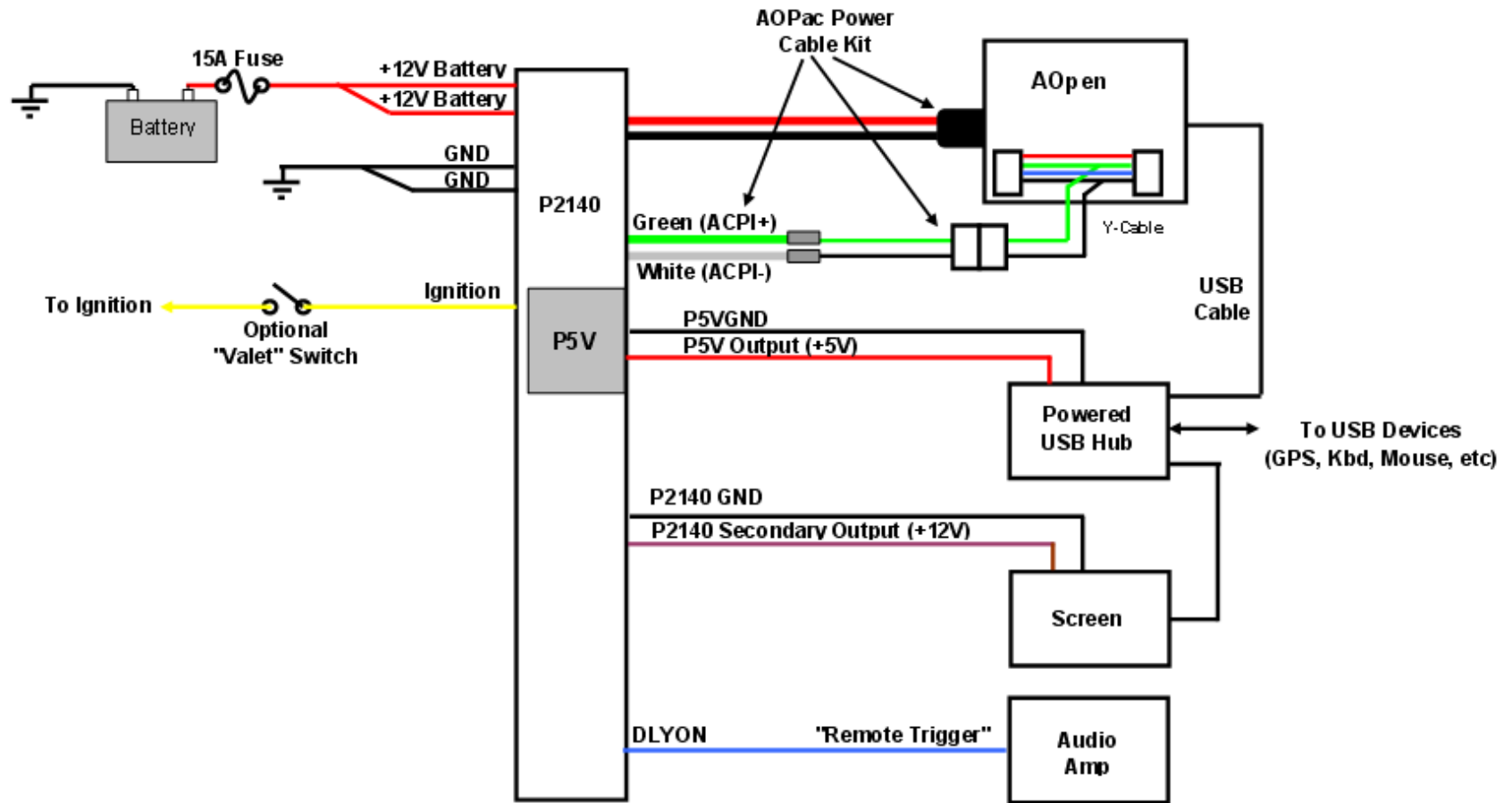

5.5 Xenarc Application Diagrams

Typical Xenarc MP-SC8 Application using CNX-CA-XSC8 Power Cable Kit

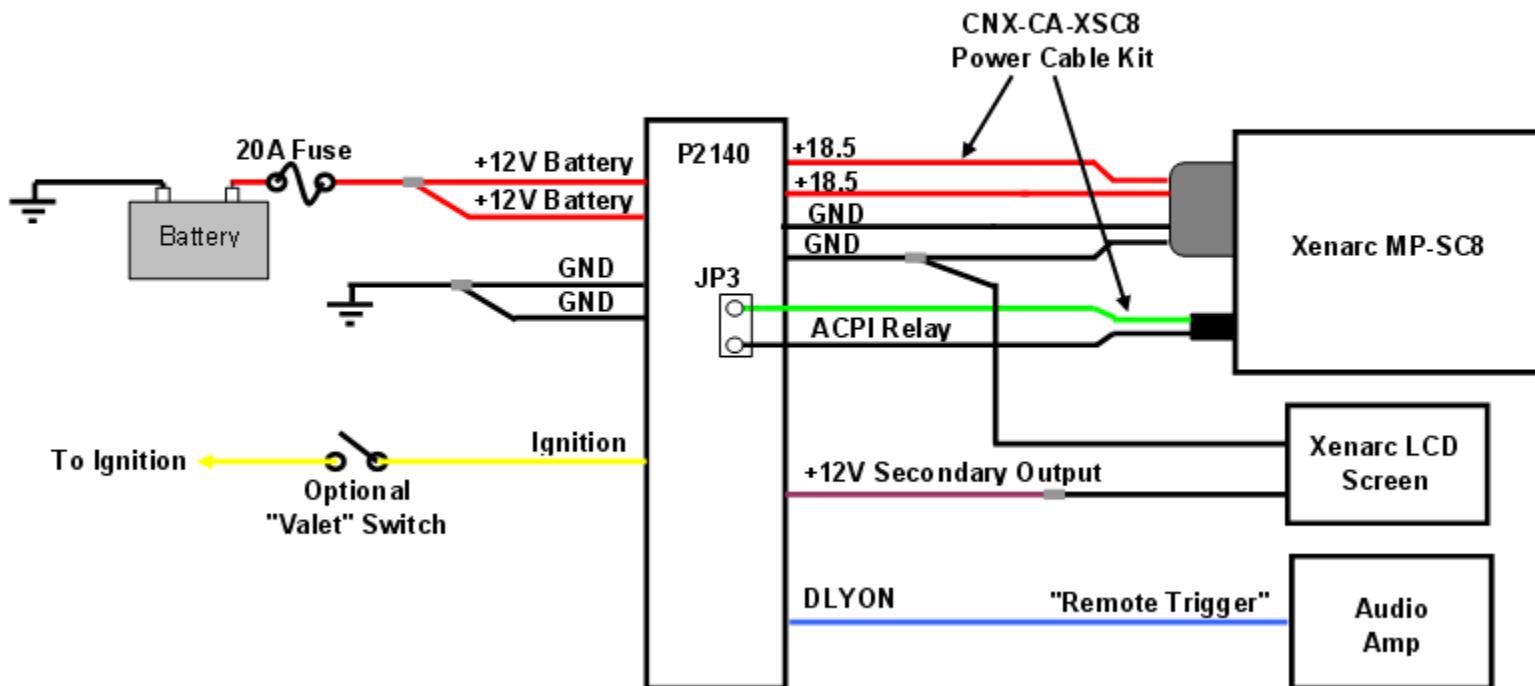

Typical Xenarc MP-SC8 Installation (Using CNX-CA-XSC8 Power Cable Kit and P5V)

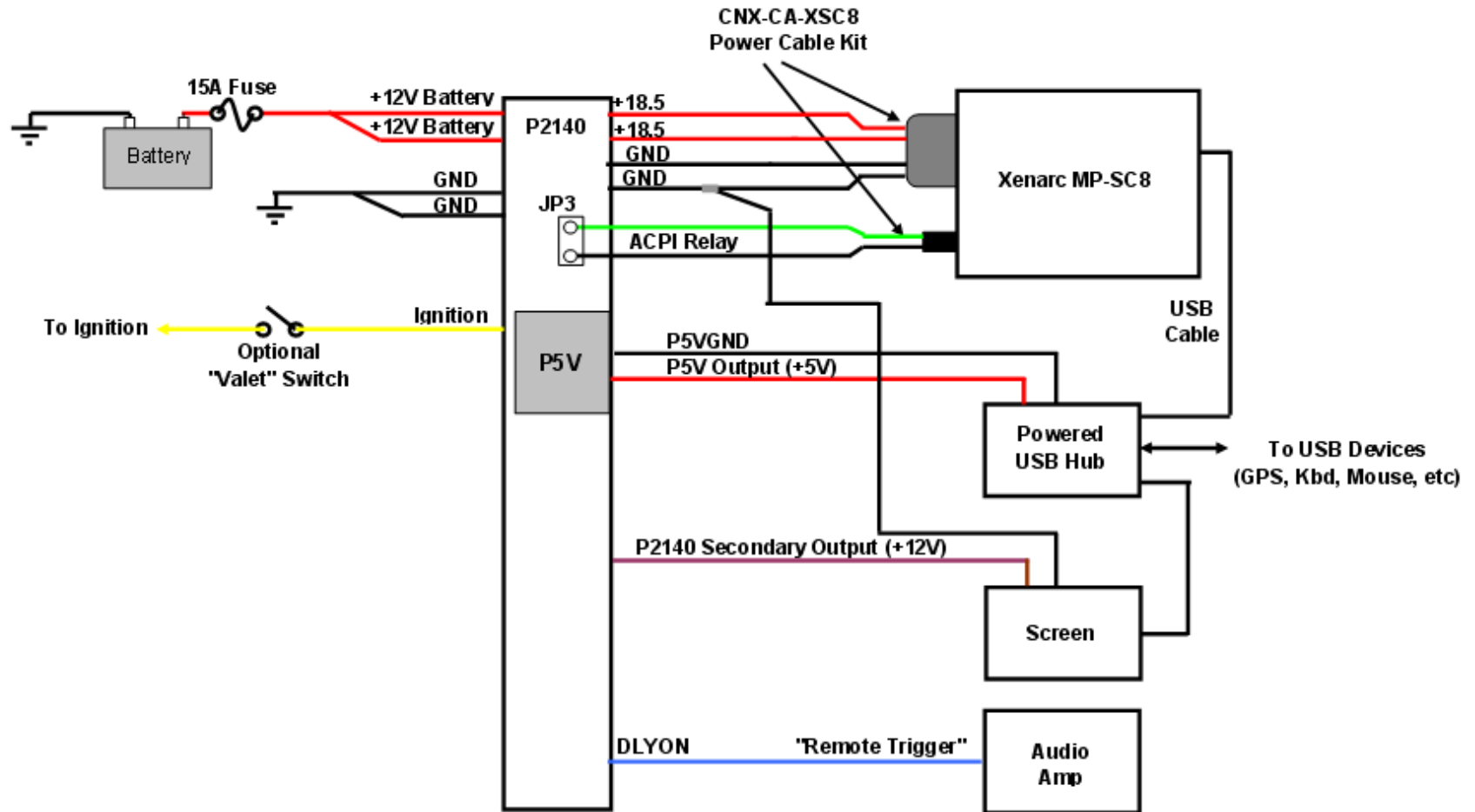



5.6 Installing a CNX-P5V in the CNX-P2140

The CNX-P5V can be added to the P2140 to provide a third regulated output. This output is typically used to power +5V USB devices, while the P2140 primary output powers the computer (+19V), and the secondary output powers your screen (+12V).

The CNX-P5V is installed into the P2140 exactly the same way as described in the P5V Installation Manual for the P1900, except for the naming of the jumpers. When following the installation instructions in the P5V manual, make the following jumper name changes.

Function	P5V Wire color	P1900 Jumper	P2140 Jumper
Battery Input	Red/Black	JP5 (pins 1&2)	JP4 (pins 1&2)
On/Off Control	Green/Black	JP4 (pins 2&3)	JP3 (pins 9&10)

See Section 3 for the location of JP3 & JP4 on the P2140.

6.0 Pulse Start Feature

The CNX-P2140 includes a feature that allows you to remotely start and stop the PSU. This feature is called “Pulse Start”. This feature would normally be used in conjunction with a wireless device such as a car alarm with auxiliary inputs/outputs or a WiFi device with Wake-On-LAN (WOL) features.

6.1 Pulse Start Connections

The Pulse Start input can either be an externally applied voltage (ie +5v or +12V) pulse, or a momentary relay contact closure. The externally applied voltage pulse is connected to Pin 1 of J1 using the Blue wire. The momentary relay contact closure is connected to Pins 1&2 of JP1 (see Section 2.2 for location). You can use either or both of these connections to start/stop the PSU.

6.2 Pulse Start Operation

6.2.1 What is a pulse?

Voltage Pulse on Pin 1 of J1

When connecting to Pin 1 of J2, the “pulse” must be a voltage that transitions from 0V to +V, ***and then transitions back to 0V***. The SSC will wait (hang) if the voltage stays high without going back to 0V after the initial transition from 0V to +V.

The value of the +V can be any voltage from approximately +2V to +20V. Typical voltages are +5V or +12V. The value of 0V must be below +.2V or open circuit (ie you could drive this input with a relay that momentarily connects to a +12V source and then provides an open circuit).

The current required to drive this input is very low (milliamps).

Contact Closure Pulse on Pins 1&2 of JP1

When connecting to Pins 1&2 of JP1, the “pulse” must be a low resistance metallic contact closure (i.e. relay) that transitions from OPEN to CLOSED, ***and then back to OPEN***. The SSC will wait (hang) if the contact closure remains CLOSED after the initial transition from OPEN to CLOSED.

The current passing through this relay is very small (milliamps) so a low power relay can be used.

Pulse Width

The pulse width can be any value from a minimum of approximately 100mSec to several seconds. As mentioned above, if the pulse is very long the SSC will wait for the transition back to the normal state before continuing.



6.2.2 Starting the PSU with a pulse

When the PSU is in Idle State and an externally applied pulse is applied to the Pulse Start input, the PSU will power up normally, as it would if the Ignition line had gone high. During the Bootup Lockout State any input pulse is ignored.

6.2.3 Stopping the PSU with a pulse

After the normal power up sequence, and while in Runs State, the SSC monitors the Pulse Start input for a shutdown pulse. If a single shutdown pulse is sensed, the PSU goes into the Shutdown Delay State. However, if control has been passed to the Ignition line (see Ignition Override below) the Pulse Start input is ignored.

6.2.4 Prolonging the Shutdown Delay State

If, while in the Shutdown Delay State, a single pulse is detected, the Shutdown Delay is restarted at its original value in order to prolong the Shutdown Delay. This is useful for occasionally downloading large files that would take longer than the normal Shutdown Delay time.

Once the Shutdown Delay has timed out, the PSU enters the Shutdown Lockout State. At this point the SSC ignores any pulse input until the PSU enters the Idle State.

6.2.5 Shutting down the PSU with double pulses

If two pulses are detected within a 5 second window during the Shutdown Delay State the PSU will skip any remaining Shutdown Delay Time and immediately enter the Shutdown Lockout Sequence. This feature is useful for shutting down the CarPC when your file transfer process is completed.

6.2.6 Ignition Override

If, after the PSU has been started by a pulse, the Ignition is turned on, control is passed to the Ignition line. Once the Ignition line has gained control of the SSC it will be able to shutdown the PSU as if it had initially started it. This feature is useful when you wish to remotely start the CarPC with your wireless device, but then get into your car and drive.



7.0 Conditions of Use

1 Year Limited Warranty

CarNetix warrants that the products it manufactures will be free from defects in materials and workmanship. The warranty term for all products is 1 Year beginning on the date of invoice. During the warranty period CarNetix will repair or replace, at our discretion, products covered under this limited warranty that are returned to CarNetix using a valid RMA number.

Service & Support

CarNetix provides a free on-line technical support forum for diagnosing hardware problems with your system throughout the warranty period. Free technical support service is limited to configuration and operation of hardware sold by CarNetix.

Returning Merchandise

If we determine that a part is defective a replacement can be after Purchaser obtains a Return Merchandise Authorization (RMA) number. Purchaser must first contact us to obtain an RMA number before attempting to return any part. Parts returned without first obtaining an RMA number shall not be accepted, repaired, or replaced.

To obtain an RMA number, Purchaser must follow these procedures

1. Email us at support@carnetix.com to receive your RMA number;
2. The RMA Number must be used within THIRTY (30) DAYS, or it will not be honored;
3. The RMA Number MUST BE SHOWN CLEARLY ON YOUR SHIPPING LABEL;
4. CarNetix must receive all Returns before a replacement will be sent, unless a valid credit card number has been given to secure payment for the replacement part;
5. Include a copy of the Invoice on which the product(s) was shipped to you;
6. All RMA Returns must be shipped to CarNetix with freight PREPAID. Any Returns with freight collect or COD will be refused and returned to you;
7. CarNetix must RECEIVE all returned goods within the warranty period.

Limitation Of Liability

This limited warranty is contingent upon proper and normal use and installation, and does not cover damage due to external causes, including but not limited to, accident, problems with electrical power, improper installation techniques or materials, liquids, chemicals, oxidation, corrosion, exposure to the elements, servicing not authorized by CarNetix, usage not in accordance with product instructions or specifications, failure to perform required preventive maintenance, and problems caused by use of parts and components not supplied by CarNetix.

CarNetix makes no express warranties or conditions beyond those stated in this warranty statement. CarNetix disclaims all other warranties and conditions, express or implied, including without limitation implied warranties and conditions of merchantability and fitness for a particular purpose. Some states do not allow limitations on how long an implied warranty lasts, so the above limitation may not apply to you.

CarNetix does not accept liability beyond the remedies set forth in this warranty statement or liability for incidental or consequential damages, including without limitation any liability for products not being available for use or for lost data or software.

Shipping & Returns



Shipping Locations and Methods

We ship both domestically (via UPS) and to most international locations (via USPS). Shipping charges do not include import taxes or customs fees. We are not responsible for loss or damage to uninsured packages. If you have a special shipping requirement or request, please notify us when you place your order or via email at sales@carnetix.com.

Return Shipping Policy

The Purchaser must pre-pay shipping and costs including insurance for any defective system or parts returned under our warranty. CarNetix shall not be liable for risk of loss or damage during shipment of your returned system or parts if you fail to insure the shipment. All products must be shipped back to CarNetix in their original or equivalent packaging. CarNetix will ship the repaired or replacement product(s) to Purchaser via Ground Service (freight prepaid) if you use an address in the continental United States. For shipments to other locations, Purchaser must pre-pay any shipping charges, insurance, export taxes, custom duties and taxes including VAT taxes, or any other charges associated with transportation of your CarNetix products. Purchaser assumes the risk of loss. CarNetix shall not be responsible for failure of the delivery service to make on-time delivery. If Purchaser requests a shipping method other than Ground Service, Purchaser must pre-pay the difference in cost before CarNetix will ship the replacement product.

Product Return Policy

If you are an end-user customer who purchased products directly from CarNetix, you may return the product to CarNetix within thirty (30) days of the purchase date for a refund of the purchase amount minus a 15% re-stocking fee. Shipping charges and insurance are not included and will not be refunded to you.

Returned products must be in as-new condition, and include all components, cables and all other items that were included with product. Failure to meet this requirement will result in an additional 10% restocking fee (25% total) being deducted from your refund. You must follow the conditions outlined below in order to obtain your refund: *Before any return, an RMA number must be obtained from CarNetix in accordance with the aforementioned RMA Policy.*

To receive a refund, the returned product must be received at our factory within thirty (30) days from the date that the RMA is issued and within ninety (90) days from the purchase date. If your product is not received within thirty (30) days of the RMA being issued, but it is received within ninety (90) days of your purchase date, then you shall be charged 25% of your invoice amount as a restocking fee. If your product is not received within ninety (90) days of your purchase date, then you shall not be entitled to any refund.

Upon CarNetix receipt of your returned product and verification that same has not been damaged, altered or is missing any other original shipping items, you will receive a refund minus re-stocking fee, normally within fourteen (14) days from the date the system is received. Your refund amount will be reduced for any missing parts, components, other original shipping items or damage or alteration to the product. CarNetix will not accept any unauthorized returns. Any merchandise returned without first obtaining an RMA number shall be rejected and returned to you at your expense.